

Timing belt conveyor with stand

TB40 - E 40 - L1000 - 5 - (200) - 20 - L H3 - A - 0 - 10 - A200 - B200 - D400 - E450 - A

Height

TB40
TB80

Drive

E = Direct drive w/ geared motor
U = Under drive w/ geared motor
E0 = Direct drive w/o motor
U0 = Under drive w/o motor

Width

40 mm profile width

Length

300 ≥ 6000 mm (5 mm interval)

No of parallel units

1-10

Conveyor c/c

Distance between units (only applicable for ≥2 units)

Speed

5, 6, 7, 8, 10, 12, 14, 16, 20, 24, 27, 32, 41, 48
(m/min at 50 Hz with standard drive)

Drive position

R = Right
L = Left

Drive orientation

See drawing on next page

H1
H2
H3
H4
V1
V2
V3
V4

Belt type

A = Plain PU on top, PA fabric on teeth
B = Linatex 2 mm on top, PA fabric on teeth
C = Linatex 4 mm (only for TB80) on top, PA fabric on teeth

Belt cleats

O = w/o cleats
FT = False teeth
CL = Bonded PU 10x32x4
CM = Bonded PU 20x32x4
CH = Bonded PU 30x32x4

Cleat c/c

Min. 10 mm interval for bonded (CL, CM, CH)
Min. 100 mm interval for false teeth (FT)

First crossbar distance (A)

(mm)

Last crossbar distance (B)

(mm)

Start height (D)

(mm)

End height (E)

(mm)

Feet

A = L-feet

Drive orientation

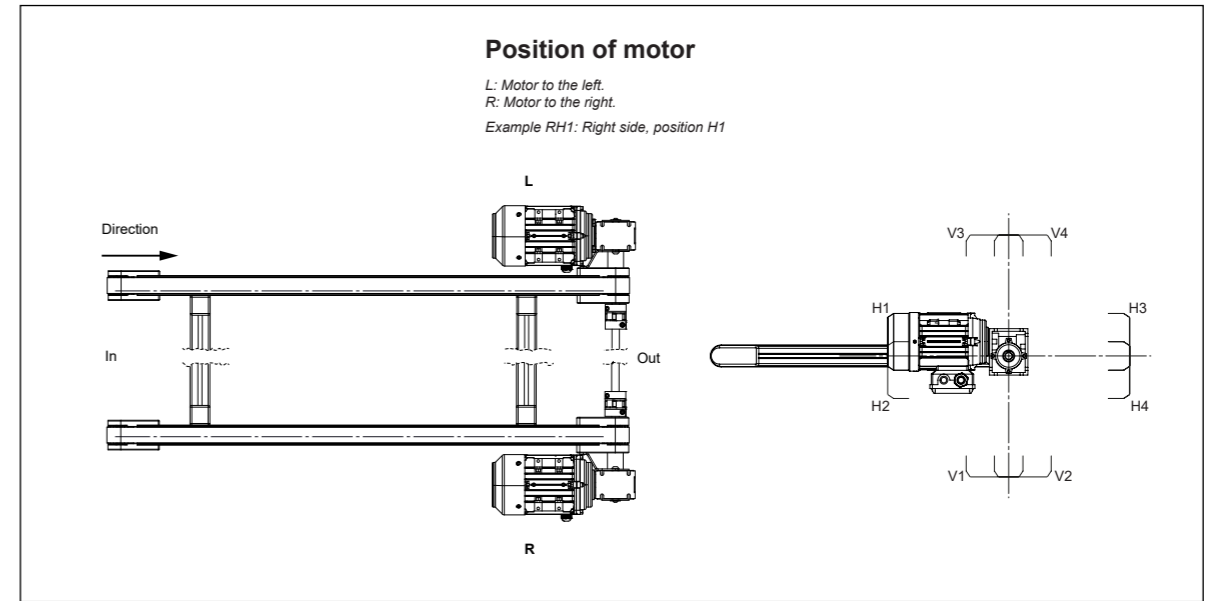

Note:

All our conveyors are skillfully adjusted and tested on our factory floor before delivery. After delivery and placement however we cannot guarantee perfect running and strongly recommend final adjustments to be made. Please see the documentation provided with the conveyor for more information on how best to do this. Note that most tracking problems occur from uneven assembly of conveyor bases or flooring and that belt tension should be maintained when adjustments made. Motors are not individually tested and not assembled to the unit during transport.

Timing belt

32AT10 -L4170 - B - CL - 30

Belt width

32 mm wide (AT10 tooth profile)

Length

(mm)

Belt type

- A = Plain PU on top, PA fabric on teeth
- B = Linatex 2 mm on top, PA fabric on teeth
- C = Linatex 4 mm on top, PA fabric on teeth (only for TB80)

Belt cleats

- 0 = w/o cleats
- FT = False teeth
- CL = Bonded PU 10x32x4
- CM = Bonded PU 20x32x4
- CH = Bonded PU 30x32x4

Cleat c/c

- 0 = w/o cleats
- Min. 10 mm interval for bonded (CL, CM, CH)
- Min. 100 mm interval for false teeth (FT)